

BRUMA

WALL SCONCE

A circular wall sconce with concentric carved ridges framing an opal glass diffuser that emits a soft, even glow. The bruma began as an exploration in green onyx, a stone that carries light the way mist moves through a valley, diffused and without origin, before moving into wood and stone.

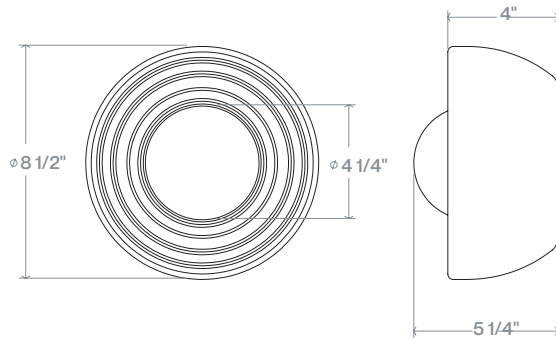

TEAK

FINISHES

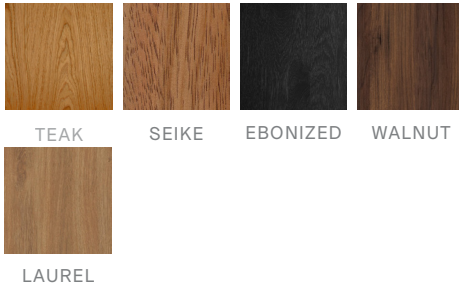

STOCK LEAD TIME 1-2 WEEKS

CORD LENGTH N/A

CERTIFICATIONS ETL - IP20 / DAMP RATED

LAMPING (X1) G9

BULB INCLUDED 120V - EA - G9 - 2.5W

DIMMING UNIVERSAL

MAX WATTAGE 25W

MOUNTING UNIVERSAL

WEIGHT ~5LBS

CUSTOMIZATIONS AVAILABLE UPON REQUEST - SALES@STUDIO-BALDO.COM